

Fine beam tube

DETERMINE THE SPECIFIC CHARGE OF AN ELECTRON

- Demonstrate the deflection of electrons in a uniform magnetic field along a closed circular path
- Determine the Helmholtz coil current I_H in relation to the accelerating voltage U of an electron gun where the electrons are moving in a circular path of constant radius r
- Determine the specific charge of an electron e/m from the measurements

UE307070

08/06 UK

BASIC PRINCIPLES

In the fine beam tube, the electrons move along a circular path in a uniform magnetic field. The tube contains neon gas at a precisely set pressure. The gas atoms are ionised along the length of the circular path due to collisions with electrons. As a result, they are excited and emit light, thereby indirectly making the circular path of the electrons visible. The radius of the path can then be measured directly with a ruler. Since the accelerating voltage U of the electron gun and the magnetic field B are known, it is possible to calculate the specific charge of an electron e/m from the radius of the circular path r .

An electron moving with velocity v in a direction perpendicular to a uniform magnetic field B experiences a Lorentz force in a direction perpendicular to both the velocity and the magnetic field.

$$F = e \cdot v \cdot B \quad (1)$$

e : elementary charge

This gives rise to a centripetal force on the electron in a circular path with radius r , where

$$F = \frac{m \cdot v^2}{r} \quad \text{and} \quad (2)$$

m is the mass of an electron.

Thus,

$$e \cdot B = \frac{m \cdot v}{r} \quad (3)$$

The velocity v depends on the accelerating voltage of the electron gun:

$$v = \sqrt{2 \cdot \frac{e}{m} \cdot U} \quad (4)$$

Therefore, the specific charge of an electron is given by:

$$\frac{e}{m} = \frac{2 \cdot U}{(r \cdot B)^2} \quad (5)$$

If we measure the radius of the circular orbit in each case for different accelerating voltages U and different magnetic fields B , then, according to equation 5, the measured values can be plotted in a graph of $r^2 B^2$ against $2U$ as a straight line through the origin with slope e/m .

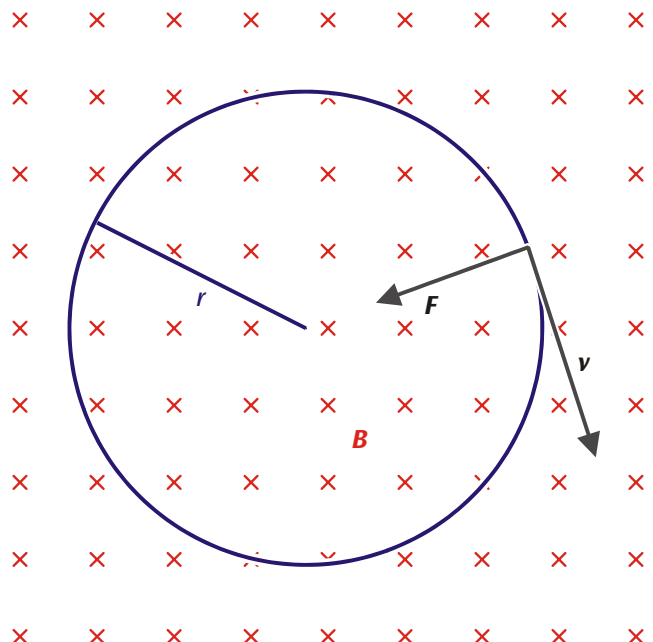

Fig. 1: Deflection of electrons moving with velocity v in a magnetic field B by a Lorentz force F along a closed circular path of radius r

LIST OF APPARATUS

1	Fine beam tube on a connector base	U8481420
1	Pair of Helmholtz coils, $d = 295 \text{ mm}$	U8481500
1	Tube power supply unit 0-300 V, 0-50 V, 4-12 V	U8521371
1	DC power supply unit, 12 V, 5 A, e.g.	U8521149
1	DC voltmeter, 300 V, e.g.	U17450
1	Set of 15 safety leads	U13802

SAFETY INSTRUCTIONS

The fine beam tube is a thin-walled, evacuated glass bulb. Handle with care: danger of implosion!

- Do not expose the fine beam tube to any mechanical stress or strain.
- In order to avoid any mechanical stress or strain, connect only one experiment lead to each contact pin.

Danger: high voltage is applied to the fine beam tube. Avoid contact with any part of the body.

- Only use safety experiment leads for connections.
- Make the connections only when the power supply unit is switched off.
- Set up or dismantle the tubes only when the power supply unit is switched off.

SET-UP

Note:

To get a clearer view of the electron beam, conduct the experiment in a darkened room.

While setting up the experiment, make sure that all power supply units are switched off and all voltage controls are turned fully to the left.

Connecting the fine beam tube to the tube power supply unit:

- Connect the 50-V output and 12-V output ground sockets (black) together.
- Connect the positive terminal of the 300-V output to the anode (red sockets) and the negative terminal to the cathode (black sockets).
- Connect the voltmeter in parallel to the 300-V output.
- Connect the negative terminal of the 50-V output to the Wehnelt cylinder (blue sockets).
- Connect the positive terminal of the 12-V output to the cathode heater (green sockets).
- Connect the PE socket of the tube power supply unit to the PE socket of the fine beam tube.

Connecting the pair of Helmholtz coils:

- Connect the coils in series to the 12-V DC power supply unit, as shown in Fig. 3, so that equal current passes through both coils.

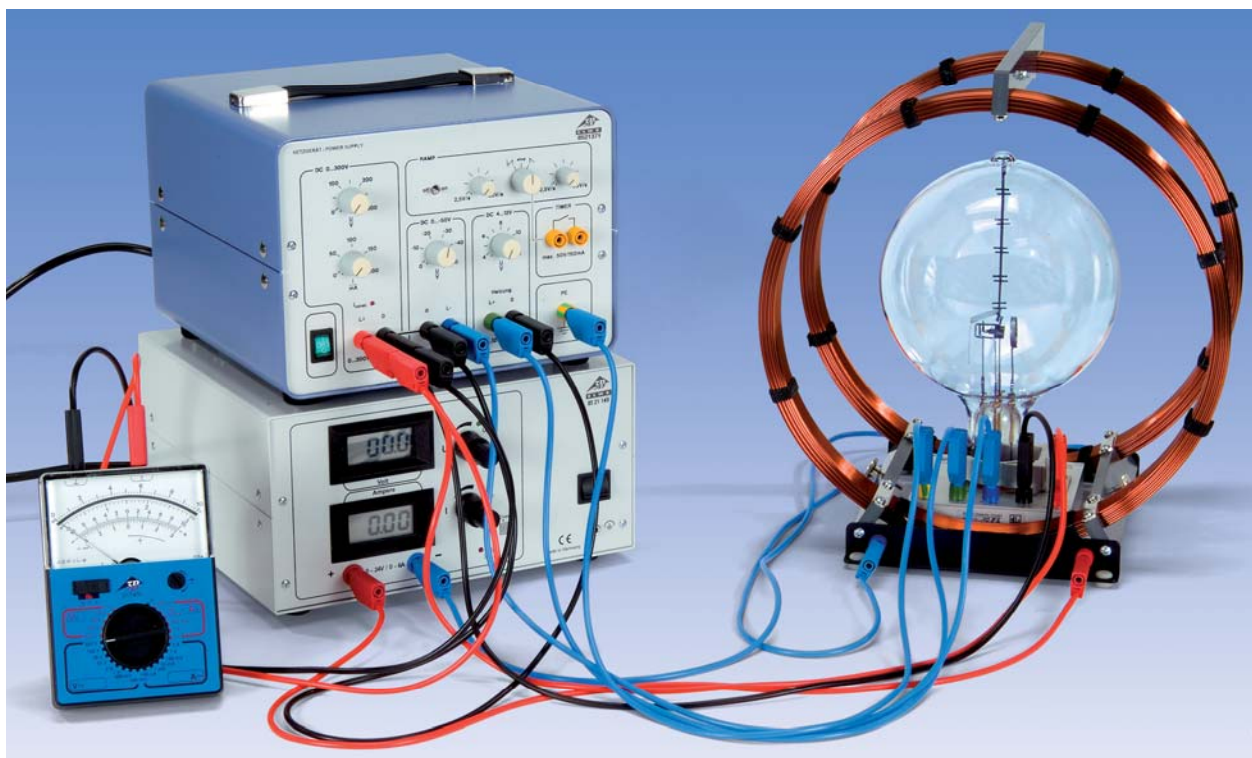

Fig. 2: Experiment set-up for determining the specific charge of an electron

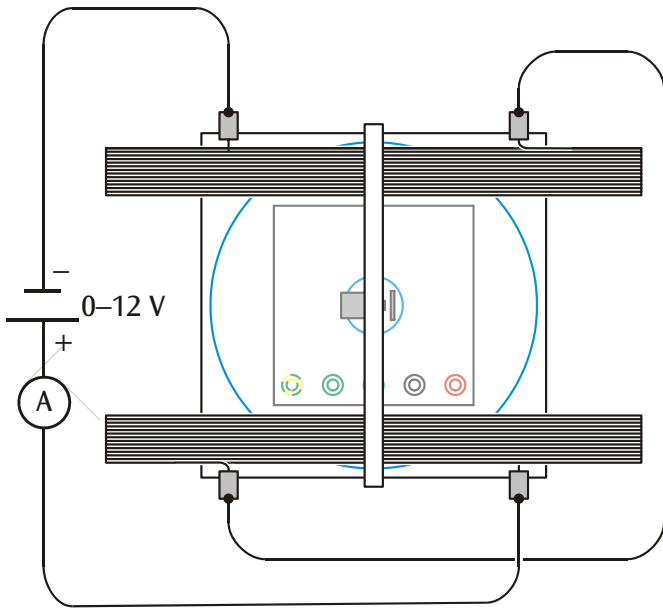

Fig. 3: Electrical connections to the pair of Helmholtz coils

EXPERIMENT PROCEDURE

Adjusting the electron beam:

- Apply a heater voltage of say 7.5 V.
- Set the anode voltage to 300 V (the electron beam is initially horizontal and is visible as a weak, bluish ray).
- Set the Wehnelt voltage so that a very clear and narrow electron beam is visible.
- Optimise the focus and brightness of the electron beam by varying the heater voltage.
- Increase the current I_H passing through the Helmholtz coils and check that the electron beam curves upwards.

If the electron beam is not deflected at all:

- Reverse the polarity of one of the coils so that current passes in the same direction through both coils.

If the electron beam does not curve upwards:

- Swap the connections on the 12-V DC power supply unit to reverse the polarity of the magnetic field.
- Continue increasing the current passing through the coils watch until the electron beam forms a closed circle.

If the path does not form a closed circle:

- Slightly turn the fine beam tube, along with its base, around its vertical axis.

Recording measurements:

- Select the current passing through the coils so that the radius of the circular path coincides with the corresponding marking on the fine beam tube. Note the set current value.

- Decrease the anode voltage in steps of 20 V to 200 V. In each case, set the coil current I_H so that the radius remains constant. Take down these values.
- Record other series of measured values for radii of 4 cm and 3 cm.

SAMPLE MEASUREMENTS

Table 1: measurements of coil current I_H in relation to accelerating voltage U for circular paths of three different constant radii

U/V	I_H/A		
	$r = 3 \text{ cm}$	$r = 4 \text{ cm}$	$r = 5 \text{ cm}$
300	2.66	1.98	1.58
280	2.56	1.91	1.53
260	2.47	1.84	1.46
240	2.37	1.77	1.42
220	2.29	1.68	1.34
200	2.14	1.61	1.25

EVALUATION

The magnetic field B generated in a pair of Helmholtz coils is proportional to the current I_H passing through a single coil. The constant of proportionality k can be determined from the coil radius $R = 147.5 \text{ mm}$ and the number of turns $N = 124$ per coil:

$$B = k \cdot I_H \text{ where } k = \left(\frac{4}{5}\right)^{\frac{3}{2}} \cdot 4\pi \cdot 10^{-7} \frac{\text{Vs}}{\text{Am}} \cdot \frac{N}{R} = 0,756 \frac{\text{mT}}{\text{A}}$$

Thus, all parameters for the specific charge are known.

For further evaluation, the measured values are plotted in a graph of $r^2 B^2$ against $2U$ (see Fig. 4). The values calculated from the measurements in Table 1 are listed in Table 2.

From the slope of the straight line through the origin in Fig. 4, we get:

$$\frac{e}{m} = 16.8 \cdot \frac{\text{V}}{\text{mT}^2 \cdot \text{cm}^2} = 1.68 \cdot 10^{11} \frac{\text{As}}{\text{kg}}$$

The reference value is specified by:

$$\frac{e}{m} = 1,76 \cdot 10^{11} \frac{\text{As}}{\text{kg}}$$

Table 2: Values calculated from Table 1 in relation to accelerating voltage U for circular paths of three different constant radii

U/V	$2U/V$	$B^2 r^2 / \text{mT}^2 \text{cm}^2$		
		for $r = 3 \text{ cm}$	for $r = 4 \text{ cm}$	for $r = 5 \text{ cm}$
300	600	36.4	35.8	35.7
280	560	33.7	33.4	33.4
260	520	31.4	31.0	30.5
240	480	28.9	28.6	28.8
220	440	27.0	25.8	25.7
200	400	23.6	23.7	22.3

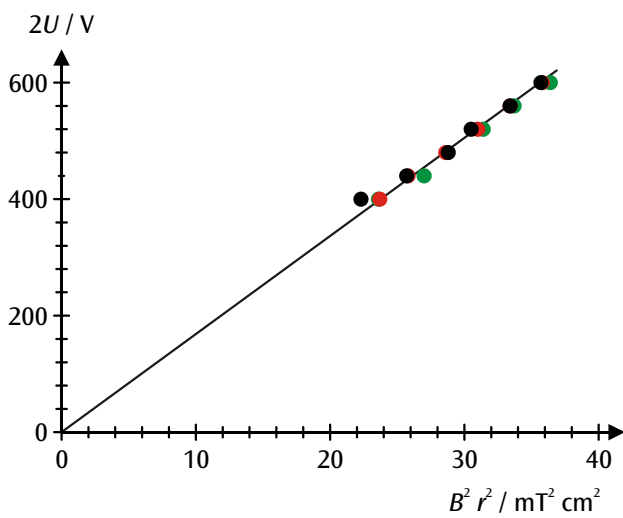

Fig. 4: Graph of $r^2 B^2$ against $2U$ for values as measured (black: $r = 5 \text{ cm}$, red: $r = 4 \text{ cm}$, green: $r = 3 \text{ cm}$)
The slope of the straight line through the origin corresponds to the specific charge of the electron e/m .